

TABLE OF CONTENTS

General	2
Preparation	2
Included in Package	2
Precautions	2
Safety Precautions	2
Static Discharge Precautions	2
Mounting	2
Environmental Requirements	2
Physical Mounting	3
<i>DIN Rail Mounting</i>	3
<i>Tab Mounting</i>	4
Removing and Replacing the Cover	4
Board Layout	4
Expansion Options	4
Option Cards	4
<i>Mounting Option Cards</i>	5
Plug-On Modules	5
Wiring Details	6
Grounding	6
Power Wiring	6
<i>CLAXWPMEU and CLAXWPMUK</i>	7
<i>CLAXNBPPWR</i>	7
<i>CLAXHAWKIO34</i>	7
Communications Wiring	7
<i>Ethernet</i>	7
<i>Serial</i>	8
Power Up and Initial Checkout	8
Connect the Backup Battery	8
Apply Power	8
Check the Status LEDs	9
Battery	9
Related Documentation	10
Using Status LEDs	10
Ethernet Ports	10
Heartbeat	10
Status LED	10
Serial Ports	10
Maintenance	11
Cleaning	11
Battery Maintenance	11
<i>Replacing the Battery</i>	11
Declaration of Conformity HAWK 2xx/6xx	12

Trademark Information

LON, LONWORKS, and Neuron are trademarks of Echelon Corporation registered in the United States and other countries.

GENERAL

This document covers the mounting and wiring of CentralLine HAWK 220/230/240/250/650/660 controllers. It assumes that you are an engineer, technician, or service person who is performing control system installation.

NOTE: The software installation and configuration (setting host IP address and password, serial port configuration, and other parameters) required for a fully functioning unit is not covered in this document. Refer to the *HAWK 2xx/6xx Install & Startup Guide* for this information. See sections "Expansion Options" on page 4, and "Related Documentation" on page 10.

PREPARATION

Unpack the HAWK 2xx/6xx and its power source (separately available), which should be one of the following:

- the **CLAXNPBPWR** 24Vac/dc input/15Vdc output power module, DIN mountable; or
- the **CLAXWPMEU** or the **CLAXWPMUK** wall AC power adapter (vary by AC wall plug); or
- the **CLAXHAWKIO34** I/O module, which features an integrated power supply module.

Inspect the package contents for damaged or missing components. If damaged, notify the appropriate carrier at once and return any damaged components for immediate repair or replacement.

Included in Package

The following items are included in this package:

- a HAWK 2xx/6xx controller.
- These *HAWK 2xx/6xx Mounting and Wiring Instructions* (Product Literature No.: EN1Z-0944GE51).
- a hardware bag containing a grounding wire with quick-disconnect 0.187" female connector.

PRECAUTIONS

This document uses the following warning and caution conventions:

CAUTION Cautions remind the reader to be careful. They alert readers to situations where there is a chance that the reader might perform an action that cannot be undone, might receive unexpected results, or might lose data. Cautions contain an explanation of why the action is potentially problematic.

WARNING Warnings alert the reader to proceed with extreme care. They alert readers to situations where there is a chance that the reader might do something that can result in personal injury or equipment damage. Warnings contain an explanation of why the action is potentially dangerous.

Safety Precautions

The following items are warnings of a general nature relating to the installation and start-up of the HAWK 2xx/6xx controller. Be sure to heed these warnings to prevent personal injury or equipment damage.

WARNING Depending on power module used, the circuit powering the HAWK 2xx/6xx is 24 Vac at 50/60 Hz or 24 Vdc (if using **CLAXNPBPWR**) or from 100...240 Vac at 50/60 Hz (if using the **CLAXWPMEU** or **CLAXWPMUK** wall AC power adapters). **Disconnect power before installation or servicing to prevent electrical shock or equipment damage.** **Make all connections in accordance with national and local electrical codes. Use copper conductors only.** **To reduce the risk of fire or electrical shock, install in a controlled environment relatively free of contaminants.** **This device is only intended for use as a monitoring and control device. To prevent data loss or equipment damage, do not use it for any other purpose.**

Static Discharge Precautions

Static charges produce voltages high enough to damage electronic components. The microprocessors and associated circuitry within a HAWK 2xx/6xx controller are sensitive to static discharge. Follow these precautions when installing, servicing, or operating the system:

CAUTION Work in a static-free area. Discharge any static electricity you may have accumulated. Discharge static electricity by touching a known, securely grounded object. Do not handle the printed circuit board (PCB) without proper protection against static discharge. Use a wrist strap when handling PCBs. The wrist strap clamp must be secured to earth ground.

MOUNTING

- Mount the HAWK 2xx/6xx controller in a location that allows clearance for wiring, servicing, and module removal.

Environmental Requirements

Note the following requirements for the HAWK 2xx/6xx mounting location:

- This product is intended for indoor use only. Do not expose the unit to ambient conditions outside of the range of 0...50 °C and relative humidity outside the range 5...95% non-condensing (pollution degree 1).
- If mounting inside an enclosure, that enclosure should be designed to keep the unit within its required operating range considering a 20-watt dissipation by the controller, plus dissipation from any other devices installed in the same enclosure. This is especially important if the controller is mounted inside an enclosure with other heat producing equipment.

- Do not mount the unit:
 - in an area where excessive moisture, corrosive fumes, or explosive vapors are present.
 - where vibration or shock is likely to occur.
 - in a location subject to electrical noise. This includes the proximity of large electrical contractors, electrical machinery, welding equipment, and spark igniters, and variable frequency drives.

Physical Mounting

The following information applies to physically mounting the unit.

- You can mount the HAWK 2xx/6xx in any orientation. It is not necessary to remove the cover before mounting.
- Mounting on a DIN rail 35-mm-wide is recommended. The HAWK 2xx/6xx unit base has a molded DIN rail slot and locking clip, as do the power modules (CLAXNBPPWR) and both types of I/O modules. Mounting on a DIN rail ensures accurate alignment of connectors between all modules.
- If DIN rail mounting is impractical, you can use screws in mounting tabs on the HAWK 2xx/6xx, then in any end-connected plug-on modules (CLAXNBPPWR, etc.). Tab dimensions are on the last page of this document.

NOTE: Mount the HAWK 2xx/6xx prior to mounting any plug-on modules).

DIN Rail Mounting

The following procedure provides step-by-step DIN rail mounting instructions for the HAWK 2xx/6xx.

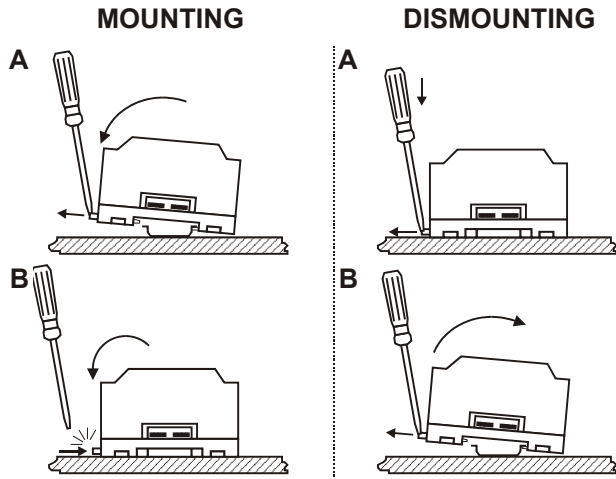

Fig. 1. Mounting/dismounting on DIN rail (recommended)

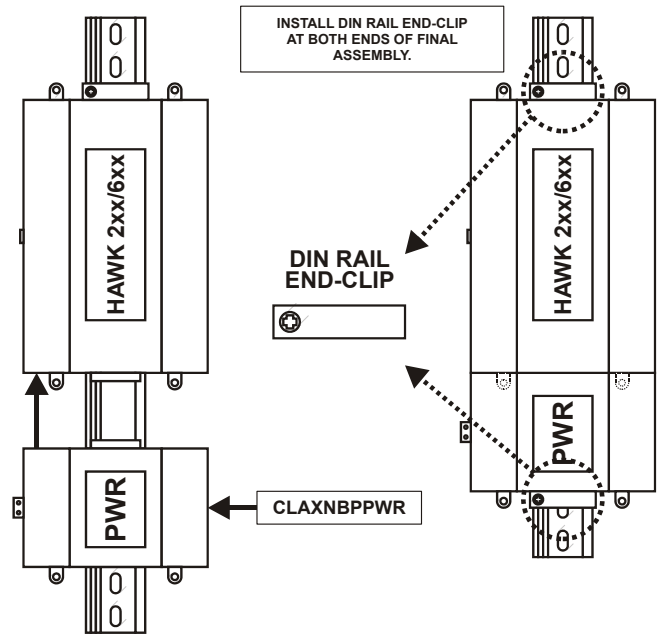

Fig. 2. Securing modules with end-clips

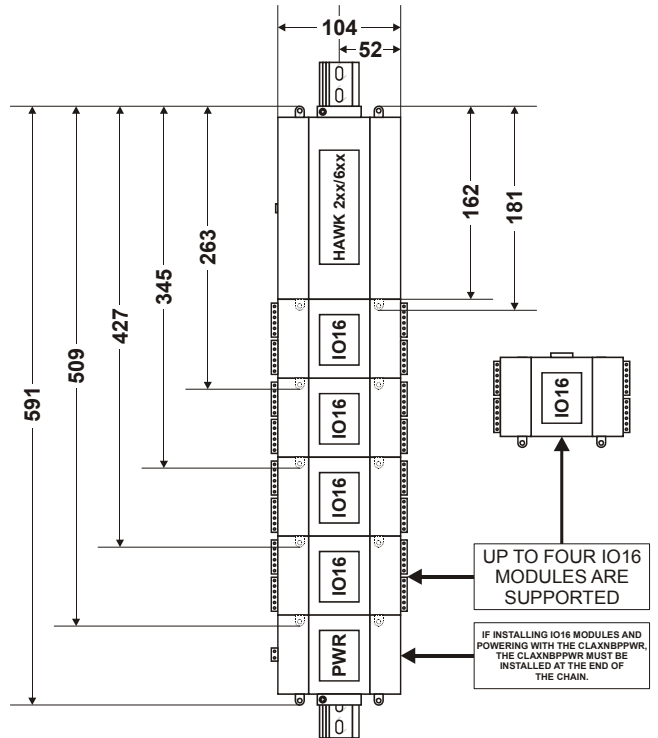

Fig. 3. Mounting dimensions

Tab Mounting

NOTE: DIN rail mounting is to be preferred over tab mounting.

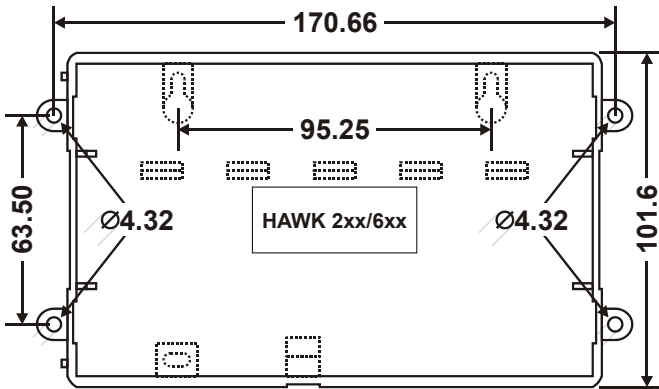

Fig. 4. Tab mounting of HAWK 2xx/6xx

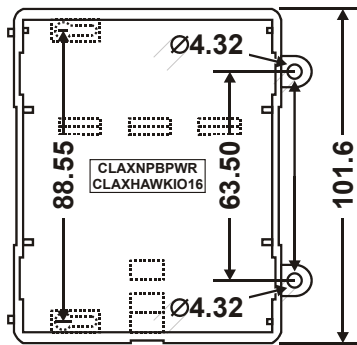

Fig. 5. Tab mounting of CLAXNPBWR / CLAXHAWKIP16

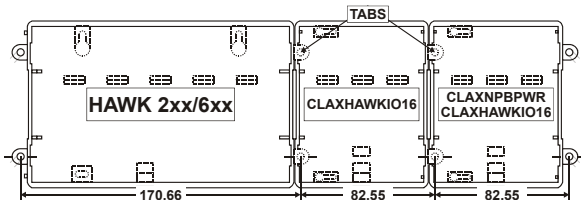

Fig. 6. Distance between centers of tabs

Removing and Replacing the Cover

In order to connect the battery (new unit) or to replace the battery, and to install any option boards, it is necessary that you remove the HAWK 2xx/6xx cover. The cover snaps onto the base with four plastic tabs (two on each end).

To remove the cover, press in the four tabs on both ends of the unit, and lift the cover off.

NOTE: If plug-on modules are connected to the HAWK 2xx/6xx, you may need to slide them away from the unit in order to access the cover tabs.

To replace the cover, orient it so the cutout area for communications ports is correct, then push inwards to snap in place.

BOARD LAYOUT

Fig. 7 shows the location of LEDs, option slots, and other features of the HAWK 2xx/6xx with cover removed.

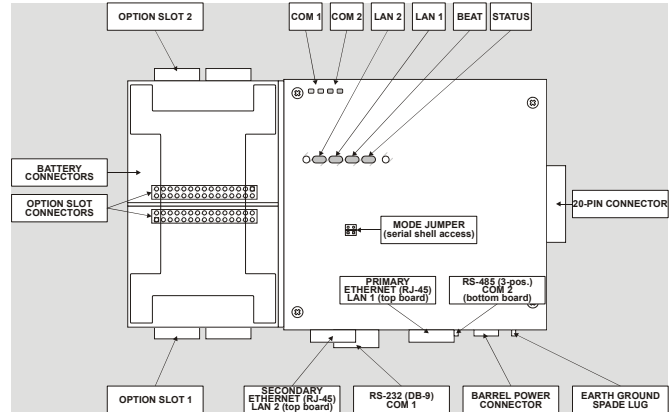

Fig. 7. HAWK 2xx/6xx board layout details.

For a side view of communications ports and other features, see Fig. 9.

EXPANSION OPTIONS

The HAWK 2xx/6xx provides for *field-installable* expansion with two kinds of options:

- **Option cards:** Install on connectors inside the HAWK 2xx/6xx controller. See section “Option Cards”.
- **Plug-on modules:** To “chain” onto the HAWK 2xx/6xx’s 20-pin connector. See Fig. 3 and section “Plug-On Modules”.

Option Cards

The HAWK 2xx/6xx has two (2) option slots for custom option cards designed for use with the HAWK 2xx/6xx. Each slot has a 30-pin connector on the HAWK 2xx/6xx base board (Fig. 7).

WARNING To prevent damage, power to the HAWK 2xx/6xx must be OFF when installing or removing option cards! Also, you must be very careful to plug an option card into its connector properly (pins aligned).

Option cards typically provide additional communications features, such as the following available models (with others still in development) listed in Table 1.

Table 1. HAWK 2xx/6xx option cards.

model	description	notes
CLAXHAWKIFLON	FTT-10A LONWORKS adapter with a 2-position removable screw-terminal connector plug.	Up to two LONWORKS option cards may be installed. <ul style="list-style-type: none"> If one LONWORKS option card is installed, it operates as LON1, regardless of slot. If two LONWORKS option cards are installed, LON1 operates as option slot 1 and LON2 operates as option slot 2.
CLAXHAWKIF485	Dual, optically-isolated, RS-485 adapter with two 3-position removable screw-terminal connector plugs.	One or two 485 option cards may be installed, with COM assignments as follows: <ul style="list-style-type: none"> If one 485 option card is installed in option slot 1, COM3 and COM4 operate as 485 ports. If one 485 option card is installed in option slot 2, COM3 and COM4 operate as 485 ports (unless the NPB-232 option card is installed in slot 1, in which case COM4 and COM5 operate as 485 ports). If two 485 option cards are installed, COM3 and COM4 operate as 485 ports for option slot 1 and COM5 and COM6 operate as 485 ports for option slot 2.
CLAXHAWKIF232	Single port RS-232 adapter, with a DB-9M connector. Uses its own on-board UART. Supports baud rates up to 115200. NOTE: NiagaraAX 3.2.11 or higher needed in HAWK 2xx/6xx.	One or two 232 option cards may be installed, with COM assignments as follows: <ul style="list-style-type: none"> If one 232 option card is installed in option slot 1, COM3 operates as a 232 port. If one 232 option card is installed in option slot 2, COM3 operates as a 232 port (unless the NPB-485 option card is installed in option slot 1, in which case COM5 operates as a 232 port). If two 232 option cards are installed, COM3 operates as a 232 port for option slot 1 and COM4 operates as a 232 port for option slot 2.

Mounting Option Cards

For complete details, see the *mounting and wiring instructions* accompanying the specific option card. The following procedure provides a basic set of steps.

Procedure 2 Mounting option cards on a HAWK 2xx/6xx.

- Step 1** Remove power from the HAWK 2xx/6xx—see the previous WARNING.
- Step 2** Remove the cover. See "Removing and Replacing the Cover," page 6.
- Step 3** Remove the battery and bracket assembly by taking out the four screws holding it in place, setting the screws aside for later. Unplug the battery from the connector on the HAWK 2xx/6xx.
- Step 4** Remove the blanking end plate for the slot you are installing the option card into. (Retain the blanking plate in case the option card must be removed at a later date.)
- Step 5** Carefully insert the pins of the option card into the socket of the appropriate option card slot. The mounting holes on the option board should line up with the standoffs on the base board. If they do not, the connector is not properly aligned. Press until the option card is completely seated.
- Step 6** Place the custom end plate that came with the option card over the connector(s) of the option card.
- Step 7** Plug the battery connector plug into the battery connector on the HAWK 2xx/6xx.
- Step 8** Set the battery and bracket assembly back over the option card slots, with the mounting holes aligned with the standoffs.

Step 9 Place the four screws through the battery bracket, end plates, and into the standoffs on the HAWK 2xx/6xx base board. Hand tighten these screws.

Step 10 Replace the cover.

Plug-On Modules

The HAWK 2xx/6xx has a 20-pin, right-angle, Euro-DIN connector that accepts custom-built plug-on modules. The connector provides power and signal lines to any connected modules, and is located on the end of the HAWK 2xx/6xx opposite to the option cards.

WARNING Power to the HAWK 2xx/6xx must be OFF when inserting or unplugging plug-on modules. Wait for all LED activity to stop (all LEDs to be OFF). Also, do not connect live voltages to the inputs or outputs of an I/O module (CLAXHAWKIO16 or CLAXHAWKIO34) while it is in an "un-powered state" before plugging the module into a HAWK 2xx/6xx. Otherwise, damage to the I/O module and/or the HAWK 2xx/6xx controller may result!

Each plug-on module has a DIN-mount base, and typically provides two 20-pin connectors that allow you to "chain" multiple plug-on modules (see Procedure 1 on page 4). Table 2 lists the currently available plug-on modules.

Table 2. HAWK 2xx/6xx plug-on modules.

model	description	notes
CLAXNBPPWR	DIN-mountable, 24V isolated power module, used to power HAWK 2xx/6xx from a dedicated, external, Class-2, 24Vac transformer or a 24Vdc power supply.	<ul style="list-style-type: none"> • Only one CLAXNBPPWR per HAWK 2xx/6xx. • Do not install if using CLAXWPMEU or CLAXWPMUK • Wiring is covered in <i>this document</i>, see "CLAXNBPPWR," page 10.
CLAXHAWKIO16	DIN-mountable, 16-point I/O module, used to provide I/O points as noted.	<p>Provides the following I/O points:</p> <ul style="list-style-type: none"> • eight Universal Inputs (UIs). • four Digital Outputs (DOs), SPST-relay type. • four Analog Outputs, 0...10Vdc type. <p>Up to four (maximum) CLAXHAWKIO16 plug-on modules are supported.</p> <p>Wiring is covered in a separate document, see the <i>IO-16 Installation and Configuration Instructions</i>.</p>
CLAXHAWKIO34	DIN-mountable, combined 34-point I/O with integrated 24V isolated power module, used to provide I/O points as well as to power HAWK 2xx/6xx from a dedicated, external, Class-2, 24Vac transformer or a 24Vdc power supply.	<p>Only one CLAXHAWKIO34 per HAWK 2xx/6xx. Provides the following I/O points:</p> <ul style="list-style-type: none"> • sixteen Universal Inputs (UIs). • ten Digital Outputs (DOs), SPST-relay type. • eight Analog Outputs, 0...10Vdc type. <p>Up to two additional CLAXHAWKIO16 modules can be used. Do not power the CLAXHAWKIO34 if using CLAXWPMEU or CLAXWPMUK.</p> <p>Wiring is covered in a separate document, see the <i>IO34 Installation and Configuration Instructions</i>.</p>

WIRING DETAILS

See Fig. 7 to locate connectors and other components on the HAWK 2xx/6xx controller.

Make connections to the HAWK 2xx/6xx in the following order.

1. Install any option boards (LON, RS-485, or RS-232) in option slots 1 and 2. See "Mounting Option Cards," page 7 for a general procedure. For complete details, refer to the specific mounting and wiring guide that shipped with the option board.
2. Connect supplied earth grounding wires (with spade connector) from the earth ground lug on the HAWK 2xx/6xx and any plug-on modules (if used) to a nearby earth grounding point. See "Grounding" for details.
3. Prepare power wiring (leave the unit powered off). See "Power Wiring" for details.
4. Connect communications cables. See "Communications Wiring," page 12 for ports available on the HAWK 2xx/6xx controller. For ports on any installed option board (LON, RS-485, or RS-232), see the specific mounting and wiring guide for any additional details.
5. If I/O plug-on modules are installed, connect the I/O wiring. Refer to the appropriate mounting and wiring guide for complete details.
6. Connect the backup battery to the HAWK 2xx/6xx battery connector, and apply power to the unit. See "Power Up and Initial Checkout," page 15.

Grounding

An earth ground spade lug (0.187") is provided on the base of the HAWK 2xx/6xx for connection to earth ground. For

maximum protection from electrostatic discharge or other forms of EMI, connect the supplied earth grounding wire to this lug and a nearby earth ground (see Figure 3 on page 11). Keep this wire as short as possible.

Power is provided for HAWK 2xx/6xx plug-on modules through the 20-pin accessory connectors. However, you should also connect the earth ground spade lug of *each plug-on module* to ground in the same manner.

Power Wiring

The HAWK 2xx/6xx must be powered by an approved 15 Vdc power source. This can be either an external wall AC power adapter (CLAXWPMEU or CLAXWPMUK) or a DIN-mount 24Vac/dc-powered module (CLAXNBPPWR) or the CLAXHAWKIO34.

The HAWK 2xx/6xx controller does not include an on/off switch. To apply power,

- in the case of the CLAXWPMEU or CLAXWPMUK, plug in the power connector to the HAWK 2xx/6xx.
- in the case of the CLAXNBPPWR, plug in its 2-position power connector.
- in the case of the CLAXHAWKIO34, plug in its 2-position power connector.

CAUTION To prevent damage, do not connect *both* the CLAXWPMEU or CLAXWPMUK and CLAXNBPPWR power supplies at the same time.

If desired, you can use the wall AC power adapter (CLAXWPMEU and CLAXWPMUK) in your office (to initially commission the HAWK 2xx/6xx), and then install the HAWK 2xx/6xx at the job using a CLAXNBPPWR module or

CLAXHAWKIO34 I/O module. The following sections provide more details:

- CLAXWPMEU and CLAXWPMUK (wall AC power adapter).
- CLAXNBPPWR (24Vac/dc-powered in-line module).
- CLAXHAWKIO34.

CLAXWPMEU and CLAXWPMUK

The wall AC power adapters (CLAXWPMEU and CLAXWPMUK) are self-contained, isolated, switching power supplies designed to plug into a standard building power receptacle of appropriate voltage. To supply power to the HAWK 2xx/6xx, you then simply plug the barrel connector plug from the wall AC power adapters into the barrel power connector on the HAWK 2xx/6xx base board (see Figure 5 on page 13).

CAUTION Do not plug the barrel connector plug from the CLAXWPMEU and CLAXWPMUK into the HAWK 2xx/6xx until all other mounting and wiring is completed. See "Power Up and Initial Checkout," page 15.

CLAXNBPPWR

The CLAXNBPPWR module can be used to power the HAWK 2xx/6xx (and if installed, also any CLAXHAWKIO16 modules) from a **dedicated** Class 2, 24Vac transformer, or from a 24Vdc power supply. If installing CLAXHAWKIO16 modules, the CLAXNBPPWR must be installed as the *last* (end) module in the chain (Fig. 1).

NOTE: If powering from a 24V transformer, do *not* power any other equipment with it. Otherwise, conducted noise problems may result. Also, do not ground either side of the transformer's 24V secondary.

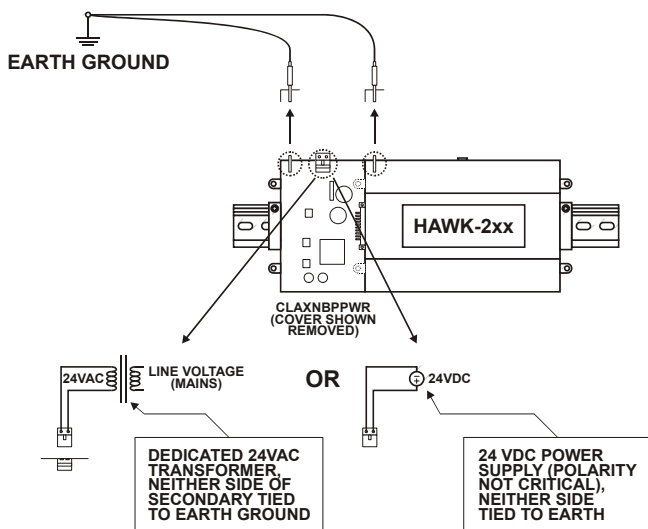

Fig. 8. CLAXNBPPWR module wiring connections.

Located at the bottom of the CLAXNBPPWR module is a 2-position power connector, and an earth ground spade lug (Fig. 8).

Connect the supplied earth ground wire to a nearby earth ground point. Unplug the power connector plug from the module and make connections to it as shown in Fig. 8.

Caution To prevent injury, do not plug 24 V power into the CLAXNBPPWR (reinsert connector plug) until all other mounting and wiring has been completed. See "Power Up and Initial Checkout," page 15.

Power consumption depends on installed plug-on modules and option boards, and may vary from:

- HAWK 2xx/6xx with the CLAXNBPPWR module alone: approx. 8.5 VA (AC) or 8.5 W (DC)
- HAWK 2xx/6xx with CLAXNBPPWR and four (4) CLAXHAWKIO16 modules, plus option boards: up to 20 VA (AC) or 20 W (DC)

CLAXHAWKIO34

See Table 2.

Communications Wiring

Connect communications wiring to the HAWK 2xx/6xx using ports on the bottom of the unit (Fig. 9), which include:

- Ethernet
- Serial

NOTE: Prior to connecting cables, provide strain relief for them to prevent damage to the controller.

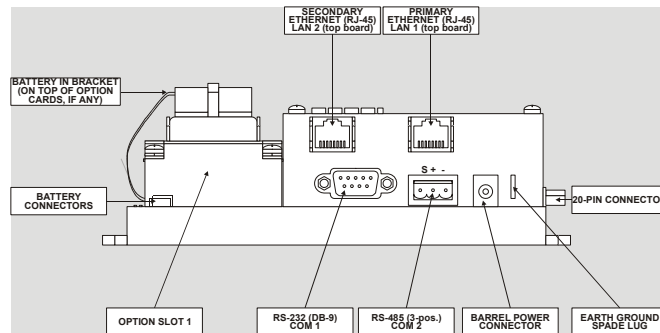

Fig. 9. HAWK 2xx/6xx (side view, cover removed).

Ethernet

Two, female 10/100-Mbit Ethernet connections are provided on the HAWK 2xx/6xx. These are RJ-45 connectors labeled LAN2 and LAN1. Use a standard Ethernet patch cable for connecting to a hub or Ethernet switch. An activity LED for each Ethernet port is visible, and are labeled "LAN2" and "LAN1" on the cover.

The factory-default IP address for **LAN1** on a HAWK 2xx/6xx is 192 . 168 . 1 . 12n, where the last numeral n in the address matches the HAWK 2xx/6xx's serial number, and subnet mask is 255 . 255 . 255 . 0. By default, LAN2 on a HAWK 2xx/6xx is disabled. Refer to the *HAWK 2xx/6xx Install & Startup Guide* for details on changing the IP address.

NOTE: Typically, you *only use LAN1* (primary port), unless you have a specific application for isolating a driver's network traffic to a separate LAN, using LAN2. Do *not use LAN2* as the primary port.

Serial

There are two serial ports on the HAWK 2xx/6xx controller. Each has a UART capable of operation up to 115,200 baud. At the bottom of the board (see Fig. 9), the left port is an RS-232 port using an DB-9 plug (male) connector. To the right of this is a two-wire with shield, isolated RS-485 port, using a screw-terminal connector plug.

NOTE: A green "receive" LED and yellow "transmit" LED are provided for each serial port. These LEDs are located on the bottom board, on the *opposite side* of the serial connectors (see Fig. 7). These LEDs are labeled on the board (COM1, COM2) and are not visible with the cover on.

RS-232—An RS-232 serial port using a male DB-9 connector always operates as COM1. You can use standard DB-9 serial cables with this port. The HAWK 2xx/6xx is a serial DTE device, such as another DTE device (PC, for example) requires a "null modem" cable. If connecting the HAWK 2xx/6xx to a DCE device (modem, for example), a straight-through cable is used. Table 3 provides standard serial DB-9 pinouts.

NOTE: If a modem option card (NPB-MDM) is installed, this port becomes disabled—except if rebooted with the mode jumper (see Fig. 7) in the "Serial Shell" position.

Table 3 Serial port (RS-232 and RS-485) pinouts.

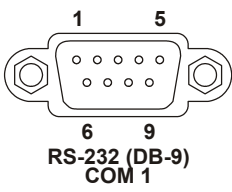
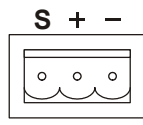
Base RS-232 DB-9 Port (COM1)			Base RS-485 Port (COM2)
pin-out references	signal	DB-9 plug pin	pin-outs
 <p>RS-232 (DB-9) COM 1</p>	DCD	Data carrier detect	 <p>RS-485 (3-pos.) COM 2</p>
	RXD	Receive data	
	TXD	Transmit data	
	DTR	Data terminal ready	
	GND	Ground	
	DSR	Data set ready	
	RTS	Request to send	
	CTS	Clear to send	
		not used on the HAWK 2xx/6xx	

RS-485—An RS-485, optically isolated port uses a 3-position, screw terminal connector and always operates as COM2. Wire to this connector with shielded 18-22AWG wiring (refer to the TIA/EIA-485 standard). As shown in Table 3, the screw terminals (from left-to-right) are shield, plus (+), and minus (-).

POWER UP AND INITIAL CHECKOUT

Ensure power wiring to the HAWK 2xx/6xx is ready—see the "Power Wiring" section on page 10. Refer to Fig. 7 for the locations of the HAWK 2xx/6xx battery connector, status LEDs and barrel power connector (for CLAXWPMEU, CLAXWPMUK wall AC power adapters, only). Refer to Fig. 8 for location of the power connector on the CLAXNBPPWR module.

Following all mounting and wiring, perform the following:

Procedure 4 Initial power up and checkout

- Step 1** Connect the Backup Battery.
- Step 2** Apply Power.
- Step 3** Check the Status LEDs.

Connect the Backup Battery

With the cover removed from the HAWK 2xx/6xx (see "Removing and Replacing the Cover," page 6), locate the red and black wires coming from the backup battery, with 2-position connector plug. Insert the plug into the battery connector on the bottom board (below option slot 2 area), as shown in Fig. 10.

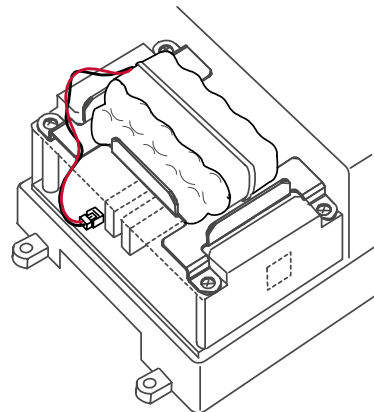

Fig. 10. Backup battery connector on HAWK 2xx/6xx bottom board.

The connector is keyed—you cannot insert it incorrectly. The red (positive) connection should be the furthest from the two 30-pin option board connectors. For more battery details, see "About the Battery," page 16.

Apply Power

Apply power to the HAWK 2xx/6xx by plugging the power plug into either the HAWK 2xx/6xx (if CLAXWPMEU und CLAXWPMUK wall AC power adapters) or the 24V-powered CLAXNBPPWR module.

CAUTION Do not connect *both* the CLAXWPMEU and CLAXWPMUK wall AC power adapters and the CLAXNBPPWR power module at the same time, or equipment damage may result, or a power outage may go unrecognized.

Check the Status LEDs

When power is applied, the green LED labeled "STATUS" will light. This indicates that the system is OK and that power is applied. Once the HAWK 2xx/6xx boots, the yellow "BEAT" (heartbeat) LED will begin blinking, with a typical rate of about 1 Hz. Blinking should begin within 30 seconds after power is applied.

If after applying power, the STATUS LED goes out, or if the BEAT LED comes on (steady) and stays lit longer than two minutes, contact TAC for technical assistance. See also the "Using Status LEDs" section on page 17.

Battery

The HAWK 2xx/6xx is provided with a custom 10-cell NiMH battery pack mounted to the unit (under the cover). This battery allows the HAWK 2xx/6xx to continue operation through very short power outages (a few seconds in duration). If a longer power outage occurs, the battery provides enough run time (typically: one minute) for the HAWK 2xx/6xx to backup data and then shutdown. Shutdown occurs automatically after the data is backed up to on-board flash memory.

The HAWK 2xx/6xx charges the battery during normal operation, until fully charged. Typically, the charge operation completes within 18 hours. Following a power outage, the battery is charged again, as necessary. The power and battery circuitry is monitored by a station running on the HAWK 2xx/6xx (via the PowerMonitorService). Station alarms are generated whenever primary power is lost, or if the battery is uncharged or unable to hold a sufficient charge.

The battery should be replaced approx. every three years, or more often if the unit is in a high-temperature environment.

NOTE: NiMH batteries tend to lose charge if not left in charge mode (trickle charge). Leaving the battery unconnected, or in the unit powered off, will cause the battery to fully discharge in a matter of weeks. Note that in the case of a new HAWK 2xx/6xx, it ships from the factory with a completely discharged battery. Therefore, allow at least 18 hours for the battery to charge if it has not been in a powered unit.

For more information on the use and replacement of the battery, refer to the "Battery Maintenance" section on page 18.

RELATED DOCUMENTATION

For more information on configuring and using the HAWK 2xx/6xx controller, consult the following documents:

- *RSIFLON Option Installation Sheet*
- *RSIF485 Option Installation Sheet*
- *RSIF232 Option Installation Sheet*

USING STATUS LEDs

The HAWK 2xx/6xx controller includes several LEDs that can help determine the status of the unit. They are located in two places: the top of the controller (visible through the cover), and for serial ports, on the bottom board (only with cover removed). From left-to-right, these LEDs include:

- two Ethernet Port LEDs
- one Heartbeat LED
- one Status LED
- two Serial Port LEDs

Refer to Fig. 7 for the exact locations of status LEDs on the HAWK 2xx/6xx controller.

Ethernet Ports

Each Ethernet port ("LAN2", "LAN1") has one green LED, visible on the top cover.

A "LANx" LED indicates activity on that port as follows:

- **UNLIT:** No Ethernet link is present.
- **LIT:** Ethernet link is present, but no activity on the LAN.
- **BLINKING:** Ethernet link is present with data activity on the LAN.

Heartbeat

The "BEAT" LED is located to the right of the Ethernet status LEDs, and is yellow. Under normal operation, this LED should blink about once per second. If the heartbeat LED *stays on constantly*, *does not light*, or *blinks very fast* (more than once per second), contact TAC for technical support.

Caution During boot-up, the heartbeat LED blinks in a 90% on — 10% off pattern. Do not remove power during this time or data loss may result (I/O module's firmware upgrade may be in progress).

Status LED

The "STATUS" LED is located to the right of the heartbeat ("BEAT") LED, and is green. This LED provides a CPU machine status check, and should remain lit whenever the HAWK 2xx/6xx is powered. If the STATUS LED *does not light* while power is applied, contact TAC for technical support.

Serial Ports

LEDs for the two serial ports are located on the HAWK 2xx/6xx's *bottom* board, on the *opposite side* of the RS-232 and RS-485 ports (see Figure 2 on page 6). Labels "COM1" and "COM2" correspond to the software configuration of the

COM ports. LEDs show the transmit and receive activity for the serial ports and optional modem.

NOTE: You must remove the cover to the serial port LEDs. See "Removing and Replacing the Cover," page 6.

- The **yellow** transmit LED indicates that the HAWK 2xx/6xx is *sending* data out the serial port over a communications line to a connected device.
- The **green** receive LED indicates that the HAWK 2xx/6xx is *receiving* data from a connected device.

These LEDs provide a fixed on-time when data is detected on the port. If the receive LED is on constantly, this indicates a problem with the communications channel, such as a shorted wire or reversed wiring.

MAINTENANCE

Cleaning

If dust or metal filings are present inside the unit, clean with vacuum or compressed air. Otherwise, no cleaning inside the unit is required. Optionally, if the cover becomes dirty, you can wipe it with a damp cloth and mild detergent.

Battery Maintenance

Battery life expectancy is a function of its discharge cycles (the number of discharges and their depth) and the ambient temperature of the battery during normal operation. In most applications, the battery should see relatively few discharges. Therefore, ambient temperature has more to do with determining the life expectancy of the battery than does any other factor. If the HAWK 2xx/6xx is installed in a conditioned space, the battery should provide dependable service for approx. three years (average). In an environment where the operating temperature is higher (that is, 50 °C), you should only expect the battery to last approx. one year.

The NiMH battery in the HAWK 2xx/6xx controller is delivered fully discharged. Additionally, NiMH batteries lose charge over time if not kept trickle-charged (for more details, see "About the Battery," page 16). Therefore, even a new unit (or replacement battery) will require up to 18 hours of powered operation before it can provide reliable backup power (i.e., is at full charge).

The HAWK 2xx/6xx monitors the battery and periodically loads the battery to test its ability to maintain battery-backed functions. Investigate any battery trouble message, and check the battery connections to the unit. Replace the battery as required. To order a new battery, see the "Standard Replacement Parts" section on page 19.

Replacing the Battery

The replacement NPB-BATT battery is a complete assembly, namely: a custom NiMH battery pack pre-attached to a battery bracket. See Figure 6 on page 15.

CAUTION Use only battery packs approved for use with the HAWK 2xx/6xx.

To replace the battery, proceed as follows:

Procedure 5 Replacing NiMH battery assembly on a HAWK 2xx/6xx.

- Step 1** Backup the HAWK 2xx/6xx controller's configuration to your PC using the appropriate NiagaraAX software tool (for example, Workbench).
- Step 2** Remove power from the HAWK 2xx/6xx. Wait for LED activity to stop—after several seconds, all LEDs on the HAWK 2xx/6xx should be off.
- Step 3** Remove the cover. See "Removing and Replacing the Cover," page 6.
- Step 4** Remove the old battery and bracket assembly by taking out the four screws holding it in place, setting the screws aside for later. Unplug the battery from the connector on the HAWK 2xx/6xx.
- Step 5** Plug the battery connector plug of the *replacement battery* into the battery connector on the HAWK 2xx/6xx.
- Step 6** Set the replacement battery/bracket assembly back over the option card slots, with the mounting holes aligned with the standoffs.
- Step 7** Place the four screws through the battery bracket, option card blanking plates, option cards (if any), and into the standoffs on the HAWK 2xx/6xx base board. Using a screwdriver, hand tighten these screws.
- Step 8** Replace the cover.
- Step 9** Restore power to the HAWK 2xx/6xx and verify normal operation.

DECLARATION OF CONFORMITY HAWK 2XX/6XX

Application of Council Directive:	89/336/EEC, 92/31/EEC, 73/23/EEC, 93/68/EEC		
Product Model Number:	HAWK 230/240/250/650/660 with the following: CLAXHAWKIO34, CLAXHAWKIO16, CLAXNBPPWR, CLAXHAWKIFLON		
Type of Equipment:	Information Technology Equipment		
EMC Standards Applied:	Standard EN 61000-6-4	Description Electro-Magnetic Compatibility Emissions Generic	Criteria met Complies
	EN 61000-6-2 and EN 61000-6-1, as defined below	Electro-Magnetic Compatibility Immunity	Complies, as documented below
	EN50081-2	Generic Emission Standard for residential, commercial, and light industrial environment	
	CISPR 11	Limits of Radio Disturbance - Radiated Emissions Limits of Radio Disturbance - Conducted Emissions	PASS Class A PASS Class A
	IEC 61000-4-2	E.S.D	PASS Criteria A
	IEC 61000-4-3	Radiated Field Immunity	PASS Criteria A
	IEC 61000-4-4	Electrical Fast Transient Immunity (Signal Ports) Electrical Fast Transient Immunity (AC Power)	PASS Criteria A PASS Criteria A
	IEC 61000-4-5	Surge Immunity	PASS Criteria A
	IEC 61000-4-6	Conducted Immunity	PASS Criteria A
	EN 61000-3-2	Harmonic Current	PASS
	EN 61000-3-3	Quasi-Stationary Harmonics Test, Voltage Fluctuation and Flicker	PASS
	IEC 61000-4-11	Voltage Dips Voltage Interrupts	PASS Criteria A PASS Criteria A
	IEC 61010-10-1: 90 +A1:92 + A2:95	Safety requirement for electrical equipment for measurement, control and laboratory use	PASS

Manufactured for and on behalf of the Environmental and Combustion Controls Division of Honeywell Technologies Sàrl, Ecublens, Route du Bois 37, Switzerland by its Authorized Representative:

<p>Centraline Honeywell GmbH Böblinger Straße 17 D-71101 Schönaich Tel +49 7031 637 845 Fax +49 7031 637 846 info@centraline.com www.centraline.com</p>	<p>Centraline Honeywell Control Systems Ltd. Arlington Business Park UK-Bracknell, Berkshire RG12 1EB Tel +44 13 44 656 565 Fax +44 13 44 656 563 info-uk@centraline.com www.centraline.com</p>	<p>Printed in Germany. Subject to change without notice. EN1Z-0944GE51 R0608</p>	 <p>CENTRALINE by Honeywell</p>
--	---	--	---